



## **Pre-Delivery Information Guide for Portable Spa Range**

### **Welcome and Thank You**

Congratulations on purchasing a Hot Tub from Hot Tub Care Ltd. Welcome to your very own world of tranquillity, relaxation and enjoyment.

We would like to take this opportunity to thank you for choosing Hot Tub Care to bring total relaxation to your home.

### **What does Delivery Include?**

If you have paid for the delivery and commissioning service then the tub will be delivered and set up on the same day by a team of 2 men. The installation team will position the tub (unless it is being craned into place), fill with water and plug into your socket. The installers will be available to demonstrate the fundamental operation and use of the tub, and explain the routine maintenance including basic chemical treatment. This service is only offered at the time of delivery, so it is advisable to make yourself available for these valuable instructions. If you cannot be available at the time of delivery then please consult your owner manuals for instructions for use.

The installation team will start your chemical treatment by balancing your pH level, and adding a starter dose of sanitiser. You will be provided with a Hot Tub Care Guide on delivery, which provides full details on how to maintain satisfactory water quality. It is very important you read this guide thoroughly so you understand how to keep your water safe and clean.

### **Pre-Delivery Guidelines**

Your new hot tub will be arriving shortly, and there are a number of factors and requirements that you should be aware of prior to delivery. The following guidelines should be read thoroughly to ensure your hot tub delivery goes smoothly.

#### **1. Delivery Vehicle**

The hot tub will be delivered on a flat bed Transit type vehicle. The maximum length of the vehicle is 6.3m, and maximum height 2.5m. Please ensure there is suitable space for the vehicle to park on, or next to your premises.

#### **2. Site Access**

There must be a clear level access route over hard ground, from the delivery vehicle to the desired location of the tub. Soft ground and/or one of two small steps can be overcome with a ramp. If you are unable to provide a ramp then please inform our office, and we can instruct your delivery team to bring a board to your delivery. Steep

inclines or more than one of two small steps may prevent delivery via trolley, so you may have to consider booking a crane. (Please see crane section for further details).

The tub arrives as a complete unit, and cannot be dismantled. It is moved on a trolley, and wheeled into position. The tub is positioned upright on the trolley, so the tub length becomes the height, and the tub height becomes the width. You must ensure you measure your access route to ensure adequate width, height and turning space for the tub and trolley. A diagram of the trolley is shown below:

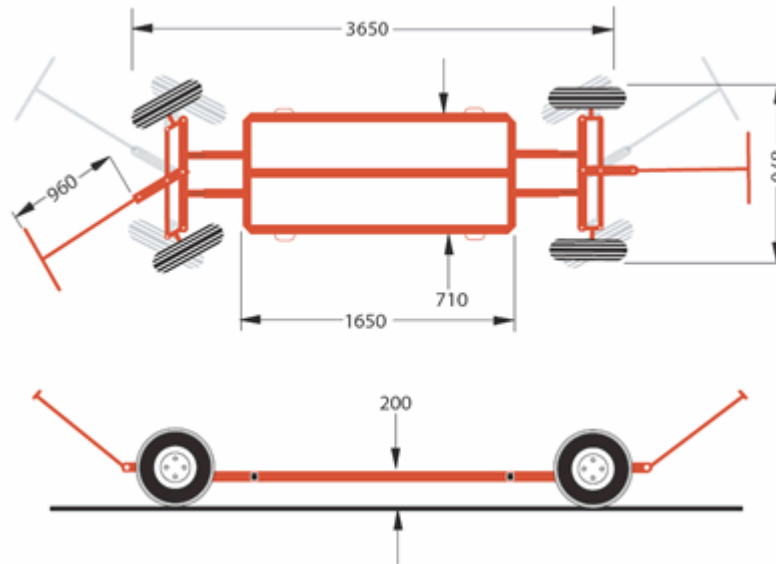

You should consider the following points when looking at your access:

- i. Is the ground sufficiently firm to support the weight of the tub and trolley?
- ii. Are there any drain covers or drain pipes which will obstruct the route?
- iii. Are there any inclines, or steps which could prevent access?
- iv. Is there adequate width on the access route? Look out for tight corners restricted by walls, fences, posts or other structures which will cause a narrowing of the route.
- v. Is there adequate height on the access route? Look out for eaves, water gutters or tree branches encroaching on height.
- vi. Make sure there are no walls which the tub needs to go over, as we cannot lift a tub over a wall under any circumstances.
- vii. Can any obstructions be moved, eg, fence panels, gates?
- viii. If access is not available through your property then would a neighbour grant access via their property?

Please consult the Model Specification table for dimensions of tubs.

**Model Specification Table**

Range	Dimensions (L x W x H) - mm	Amps	Weight (kg)	Volume (L)
Jupiter 4 Pump	2185 x 2185 x 1000	30 Amp	460	1650
Eros 3 Pump	2140 x 2140 x 900	20 Amp	350	1350
Neptune 2 Pump	2060 x 1920 x 870	13 Amp	300	1000
Neptune 3 Pump	2060 x 1920 x 870	20 Amp	300	1000
Venus 2 Pump	2060 x 1500 x 870	13 Amp	250	850
Apollo 2 Pump	1700 x 1700 x 830	13 Amp	200	700

Java	2007 x 1676 x 762	20 Amp	230	757
Adriatic	2140 x 2140 x 915	20 Amp	320	1325
Adriatic Deluxe	2140 x 2140 x 915	30 Amp	320	1325
Baltic	2140 x 2140 x 915	20 Amp	320	1325
Baltic Deluxe	2140 x 2140 x 915	30 Amp	320	1325
Caspian Range	2340 x 2340 x 915	30 Amp	365	1500

NB. Measurements shown are approximate, due to variations in bespoke manufacture.

Please remember to add the trolley dimensions to these measurements where necessary.

If you are unable to provide a clear level access, then you will have to arrange a crane lift. (Please see crane section for more details).

### 3. Positioning and Base

The hot tub needs to be positioned on a flat, level, free draining base suitable to hold the weight of the hot tub (filled and with bathers). An uneven base will cause the unit to flex and may cause irreparable damage which will not be covered under the warranty.

Where it is intended to install the spa on a concrete base it should be constructed to a minimum of 4 inches/102mm, and may need to be reinforced depending on the local ground substrate. If in doubt consult a local builder, contractor or surveyor for advice and information on the construction required. Your tub may also be placed onto paving slabs or decorative paviers providing they have been laid on a sub base suitable to support the weight of the tub.

Ours tubs can also be installed on wooden decking, however deck construction should be designed or adapted to ensure it is capable of supporting the filled and occupied weight of the tub.

Hot tubs should never be located on flooring that can be damaged by water being trapped under the tub, splashed over the tub or leaking from the tub.

If the tub is being position over a basement or on a suspended floor then you should seek the advice of a structural engineer regards the weight loading and also take into consideration the situation in case of flooding.

If the spa is in any location where a leak will cause damage then it must be placed in a bund tank or tray that will be able to contain any leak, in flow and volume, and be plumbed to a suitable drainage. This is especially so where there are floors below the tub location or if the spa is in a basement.

We may require access to all sides of the spa for servicing, so it is advisable to leave at least 1m clearance around the unit. If you are unable to allow clearance all around the unit then you may just leave access to the side housing the equipment. However if we ever need to gain access to the other sides then it is your responsibility to move the tub into a suitable position prior to an engineer visit.

You should consider that you will need room to facilitate moving the cover on and off, and extra room if you wish to fit a cover mate. You also need to be able to remove the filters without difficulty.

The natural location for this range of hot tubs is on the ground, and we do not recommend this type of tub is sunk into the ground or decking (if you are interested in an in ground tub, then please ask for details on this range). If you do decide to sink your tub, then please be aware that you must either fit a service hatch with adequate room for an engineer to access all sides of the tub, or you must be prepared to remove the spa from ground at your own cost if it ever requires servicing.

Positioning a hot tub indoors is at your own risk, and you must ensure precautions are made for leaks, access for maintenance and ventilation. The tub must be on waterproof flooring, with adequate drainage. Please note tubs are freestanding units and are not designed to be built into premises.

#### **4. Electrical Supply**

The provision of an electrical supply to the intended location of the tub is the sole responsibility of the homeowner. The electrical installation must be undertaken by a qualified electrician and confirm to IEE regulations current edition. From January 2005 the installation of new electrical circuits in dwellings came under Building Regulations known as Approved Document P- Electrical Safety, which is now a legal requirement. Under the new requirements the installation of an electrical supply must either be submitted for Building Regulation approval or Self Certified by a suitably qualified electrician.

We will supply the tub with approximately 2 metres of Steel Wire Armoured (SWA) cable, terminated with an IP67 32A plug.

Your electrician needs to adhere to the following:

- i. The cable should run to the spa location, where there should be 4 metres of extra cable terminated with an IP67 32A socket. *(The socket is included in the tub price, and will be supplied to you either by the sales person at time of sale, or posted to you soon after you place your order. Please contact us if you do not receive your socket within 5 working days of placing your order.)*
- ii. The cable size and rating should be determined by a qualified electrician depending on the length of the cable run and location. The cable must be 3 core (Twin and Earth) to suit the connection to the supplied socket. It is also advisable to use SWA cable where the cable is run externally.
- iii. Do not bring the cable up under the spa as all models sit flat on the ground, instead bring up to the side where the spa will sit.
- iv. There must be a dedicated single-phase circuit; with ampage to suit your model (see model specification table).
- v. The minimum voltage at the site of installation should be 220V and the maximum should be no more than 240V. Voltage drop must be avoided.

- vi. The electrical circuit must be protected with an RCD rated at 30mA and sized for the tub load.
- vii. The electrical supply must be installed such that if either fuse, MCB (Miniature Circuit Breaker) or RCD trips this will in no way affect the rest of the home, ie. disconnecting electrical supply to freezers, computers etc.

We also recommend you put in place a local means of isolation in the form of a waterproof switch. This will make servicing much easier in the future, as an engineer will not require access to your house. Under IEE Regulations for the electrical installation isolators, electrical outlets and equipment must be placed at least 2 metres away from the tub. The electrical supply should be installed via a fused spur protected by a suitably rated RCD.

Our hot tub installation teams are not electrical contractors and can only connect the tub to a professionally installed supply that has been tested and certified by a qualified electrician to the latest regulations.

## **5. Water Supply**

A suitable water supply must be available to fill the hot tub (usually a hose pipe).

## **Target Delivery Date**

We always endeavour to deliver on the target date provided in the order confirmation letter. However on occasions we may need to change your delivery date, but we would inform you immediately if this were the case.

If the delivery date provided is inconvenient please inform us within 3 working days of receiving the letter. We need to book labour and vehicles 1 week ahead, so we require 5 working days notice to move a delivery date. Failure to provide 5 working days notice to change a delivery date may incur a charge to cover our costs.

We would respectfully ask that you try not to change your delivery date too many times. Each change causes an additional administration cost, and if your hot tub has been manufactured then we incur storage costs. We are always happy to try and accommodate unavoidable delivery date changes, as we know unexpected personal circumstances or a contractor letting you down can force you to change your plans. However if numerous date changes are required then we will have to consider passing some of the costs we have incurred onto you.

## **Delivery Time**

We often have more than one delivery on each vehicle, and each delivery has different requirements, some of which we only discover on arrival, so we are unable to give an exact arrival time. Even when everything runs smoothly delivery schedules can be completely thrown by traffic conditions. When we encounter a succession of problems this can result in deliveries arriving late in the evening, although this is rare. Please let us know in advance if this is not acceptable.

If you wish to know an approximate delivery time then please call the office either the day before delivery, or on the day of delivery, and we can advise AM or PM, but we cannot guarantee these time periods. We are also able to issue you the mobile number of your drivers on the day of delivery so you can keep in touch.

If you would prefer an AM or PM delivery then we will always do our best to accommodate, and may on occasions be able to issue you with an approximate arrival time, but we cannot ever guarantee a time.

## **Crane Lifts**

If you are unable to provide suitable access, then you will need to book a crane to lift the tub into position. It is your responsibility to organise and pay for the crane, and we suggest you find a local company through Yellow Pages or similar directory. The price will depend on your site, and the size of crane required. Prices can vary from company to company, so it is worth contacting a few companies to compare prices.

We will make every effort to co-ordinate a delivery time which is agreeable to your crane company. We always prioritise crane deliveries, and try to make them first job of the day where possible to minimise the possibility of delays. However we can never guarantee a time, as factors outside our control such as traffic could make us late, and we will not pay compensation if this occurs. Do stress to the crane company that they may have to wait if we are delayed in traffic and ensure your arrangement does not involve punitive waiting rates.

Most mobile crane companies are familiar with lifting hot tubs, and will advise you of their requirements (if any). If they require the tub to be delivered on a pallet, then please inform us in advance so we can arrange this.

## **And Finally...**

If you are unsure about your access or anything mentioned in this guide then please contact us for advice. Failure to comply with our requirements could result in disappointment if we are unable to set up your spa as planned. Please note there is also a charge to return to site if required.